



High-Performance  
**METAL ROOFING**

**ECO-Series**  
Energy-Efficient  
High-Performance

**PBR Eco-4 & ECO Rib-5**



## INSTALLATION GUIDE & ORDERING INFORMATION

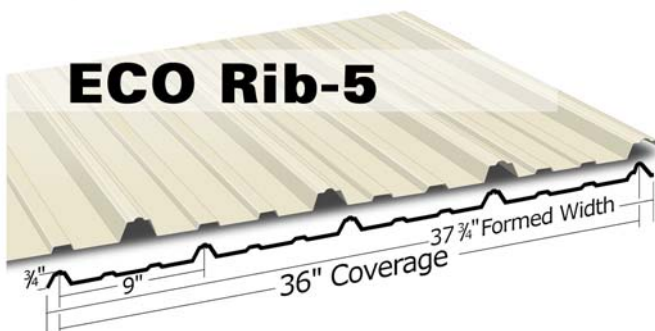
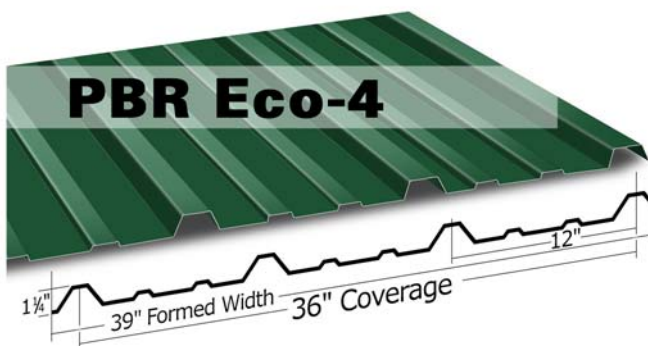

**Important Notice:** Read ALL instructions & safety warnings prior to installation. Failure to follow these steps may result in serious risk of injury.

AFP Metal Products assumes no responsibility for any problems, which might arise as a result of improper installation or any personal injury or property damage that might occur with the products use.

This guide does not replace local or state building codes.

# AFP Metal Products

## ECO Rib-5 and PBR Eco-4 INSTALLATION GUIDELINES

**Caution:** ECO Rib-5 and PBR Eco-4 roofing panels must be applied on a minimum roof pitch of 3:12 or greater for ECO Rib-5 & 1:12 or greater for PBR Eco-4.

**Important Notice:** This guide must be read in its entirety before beginning installation.

**Note:** Under certain conditions, panels may show waviness commonly referred to as “oil canning.” This is a characteristic of roll forming. Such oil canning will not be accepted as cause for rejection.

In areas of high snow or ice accumulations, snow guards, or snow blocks, may need to be added to the metal roof system to reduce or eliminate snow or ice from cascading from a higher roof and damaging lower roofs, roof valleys, gutters, or objects on the ground. Check with your installer and local building codes as to the need of snow blocks or guards in your area and design appropriately.

### MINIMUM RECOMMENDED TOOLS & EQUIPMENT

**Screw Gun**—2,000 to 2,500 rpm Clutch type screw gun with a depth sensing nose piece is recommended to insure proper installation of the screws. The following bits will be required:

- ◆ 1/4" hex magnetic socket
- ◆ 5/16" hex magnetic socket

**Snips**—For miscellaneous panel and flashing cutting requirements. Three pairs will be required: one for left edge, one for right edge, and one for centerline cuts.

**Electric Nibblers or Metal Shears**—Used for general metal cutting, such as cutting the panels in hip and valley areas.

**Note:** Some installers prefer using a circular saw with a metal cutting abrasive blade. This method may be faster, but it has some drawbacks:

1. Saw cut edges are jagged and unsightly and tend to rust more quickly than sheared edges.
2. Saw cutting produces hot metal filings that can embed in the paint and cause rust marks on the face of the panel.
3. Saw cutting burns the paint & galvanizing at the cut edge leading to the onset of edge rust.

**Chalk Line**—Used to assist in the alignment of panels, flashings, etc.

**Caulking Gun**—Used for miscellaneous caulking and sealing to inhibit water infiltration.

**Rivet Tool**—Used for miscellaneous flashing and trim applications.

**Hand Bending Tools**—Used to hand bend the ends of trim components to provide a neat, finished appearance.

**Marking Tools**—Indelible markers, pencils, or scratching tools.

**Scratch Awl**—Can be made from old screwdrivers ground to a point. Used to mark the steel, open

hems, and as a punch.

**Utility Knife**—Used for miscellaneous cutting.

**Electric Drill**—Used to drill holes such as those required for pop rivet installation.

**String Line**—Use for general alignment and measuring.

**Tape Measure**—25-foot minimum (another at 50 foot is handy).

**Locking Pliers**—Standard and “Duckbill” style for miscellaneous clamping and bending of parts.

### SAFETY CONSIDERATIONS

- ◆ **Never use unsecured or partially installed panels as a working platform.** Do not walk on panels until they are in place on the roof and all of the fasteners have been installed.
- ◆ **Metal roofing panels are slippery when wet, dusty, frosty, or oily.** Do not attempt to walk on a metal roof under these conditions. Wearing soft-soled shoes will improve traction and minimize damage to the painted surface.
- ◆ **Always be aware of your position on the roof relative to your surroundings.** Take note of the locations of roof openings, roof edges, equipment, co-workers, etc.
- ◆ **Always wear proper clothing and safety attire.** Wear proper clothing when working with sheet metal in order to minimize the potential for cuts, abrasions and other injuries. Eye protection and gloves are a must when working with sheet metal products. Hearing protection should be used when power-cutting metal panels.
- ◆ **Use care when operating electrical and other power equipment.** Observe all manufacturer’s safety recommendations.
- ◆ **Roof installation on windy days can be dangerous.** Avoid working with sheet metal products on windy days.

### DELIVERY, HANDLING & STORAGE

- ◆ Always inspect the shipment upon delivery. Check for damage and verify material quantities against the shipping list. Note any damaged material or shortages at the time of delivery.
- ◆ Handle panel bundles and individual panels with care to avoid damage. Longer bundles and panels may require two or more “pick points” properly spaced to avoid damage that can result from buckling and/or bending of the panels.
- ◆ Store the panels and other materials in a dry, well-ventilated area, away from traffic. Elevate one end of the bundle so that any moisture that may have accumulated during shipping can run off. Be sure that air will be able to circulate freely around the bundles to avoid the build-up of moisture. Never store materials in direct contact with the ground.
- ◆ Wear clean, non-marking, soft-soled shoes when walking on the panels to avoid shoe marks or damage to the finish. Step only in the flat area of the panels.

# ESTIMATING & ORDERING A ROOF

## Step 1

A. Sketch a birds-eye view of the roof and label each section (see example below.)

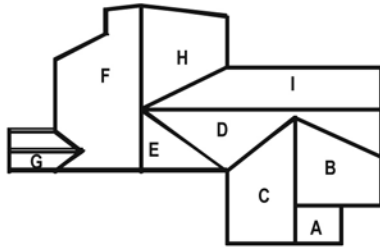

B Sketch a diagram of each roof section. Show all measurements (see example below.) **It is important to measure exact center of the ridge to the eave edge.** Do not allow anything for overhang.

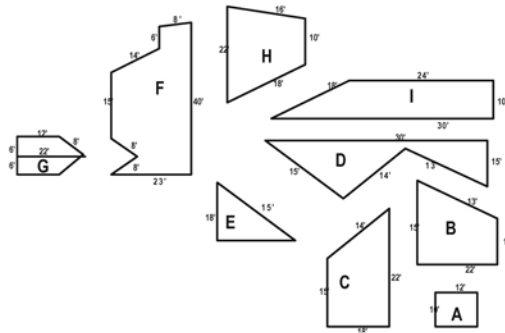

**Additional Information Required:** Roof Pitch, Skylights (Location & Size), Chimney (Location & Size), and Size and Number of Pipe Penetrations.

**Additional Identification:** Ridge, Hips, Valleys, Gables, Etc.

## Step 2

From the diagram you completed in Step 1, you are now ready to develop your roofing panel cut list. Each panel covers 36" of area so the only measurements you need are the distance from the eave to the ridge and the ridge length. You can then determine the number of panels needed by dividing the ridge length by the panel coverage. (See example Diagram "A" below.)

**DIAGRAM "A"**

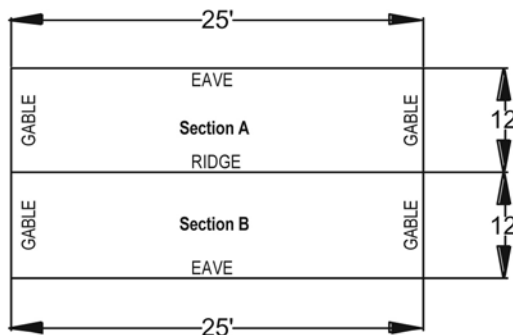

The length from the eave to the ridge is 12'. The length of the ridge is 25'; therefore, the number of panels to complete one side of the house is  $25 \div 3 = 9$  pcs. Your materials list should look like Sample "B" on page 4.

## ESTIMATING & ORDERING A ROOF

### SAMPLE "B"

Section A—9 pcs. X 12'

Now look at your roof diagram and figure out your next section of roof. Refer back to Diagram "A".

Section B of this sample roof is the same as Section A. Your materials list should now look like Sample "C" below.

### SAMPLE "C"

Section A—9 pcs. X 12'

Section B—9 pcs. X 12'

If your home has hips or valleys, refer to Diagram "1A" below.

### DIAGRAM "1A"

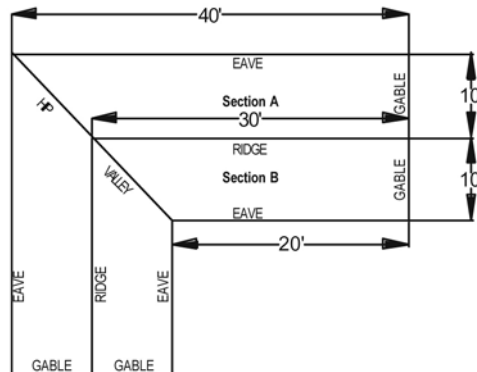

Start with section A. The eave length is 40' and the ridge length is 30', with a difference of 10'. You will need  $30 \div 3 = 10$  pcs. X 10' to reach the area where the valley starts. Remember that you have 10' remaining to cover the area. Calculate the length of each panel going into the valley by first determining the roof's pitch. Pitch is how much rise your roof has in inches for every foot of horizontal run. Use the Hip and Valley Chart below to ensure you order the correct panel length for hips and valleys. For example, Diagram "1A" is a 4/12 pitch (4/12p). According to the chart below, we know each panel will be 36 1/8" shorter. Since we are measuring from the longest point of the angle, your first piece will be the same length as the full eave to ridge measurement and each piece after will be 36 1/8" shorter. (Your list of Section A should look like Sample "D" on page 11.)

### Hip & Valley Chart

When determining the panel length needed for a hip or valley, the panel will either be shorter or longer as you go up or down the hip or valley. The chart below shows you the amount to add or subtract from each panel according to the pitch of your roof, for hips and valleys where the intersecting roof planes are at 90° to another, as in diagram 1A.

$$1/12p = 36 \frac{1}{8}" \quad 5/12p = 39" \quad 9/12p = 45"$$

$$2/12p = 36 \frac{1}{2}" \quad 6/12p = 40 \frac{1}{4}" \quad 10/12p = 46 \frac{7}{8}"$$

$$3/12p = 37" \quad 7/12p = 41 \frac{11}{16}" \quad 11/12p = 48 \frac{13}{16}"$$

$$4/12p = 37 \frac{15}{16}" \quad 8/12p = 43 \frac{1}{4}" \quad 12/12p = 50 \frac{15}{16}"$$

Note: When determining panel lengths, always round up to the next full inch.

## ESTIMATING & ORDERING A ROOF

### SAMPLE "D"

Section A 11 pcs. X 10'  
1 pc. X 7'  
1 pc. X 4'  
1 pc. X 1'

### Step 3

Refer to the Home Legend of pages 11-12 for trim placement. From this diagram, you can determine the names and placement of the trim needed. All trim is produced in 10' 6" sections only. Use the estimating section to determine trim quantities.

For applications of the trim flashings, see pages 19-21.

### ECO 5-Rib and PBR Eco-4 Estimator/Order Guide

#### Accessories

Determine the total lineal feet of each condition listed below and then fill that number in on each line. Use the equations on pages 13—15 to calculate the number of pieces for each item and circle the flashing design required.

Eave \_\_\_\_\_ Sidewall \_\_\_\_\_ Gambrel \_\_\_\_\_  
Ridge \_\_\_\_\_ Endwall \_\_\_\_\_ Skylight/Chimney width = \_\_\_\_\_  
Hip \_\_\_\_\_ Valley \_\_\_\_\_  
Gable \_\_\_\_\_ Transition \_\_\_\_\_

Slope Transition:  $\text{ft} \div 10 = \text{pcs TATRF-1 TRANSITION TRIM}$

Gambrel:  $\text{ft} \div 10 = \text{pcs TDGT-1 GAMBREL TRIM}$

At this point, your materials list for Diagram "A" should look like Sample "E".

**SAMPLE "E"**

Panels:

Section A 9 pcs. X 12'  
Section B 9 pcs. X 12'

Trim:

6 pcs. TAE-1 Eave Trim 5/12p  
3 pcs. TARC-1 Ridge Cap 5/12p  
6 pcs. TAMG-1 Gable Trim  
700 pcs. #14 x 1" Panel Screws  
200 pcs. #14 x 1" Trim Screws  
100 pcs. #14 x 1.5" Trim Screws  
4 Rolls Butyl Sealant Tape  
17 pcs. Inside Closure  
1 Roll (100') Profile Vent ECO Rib-5 & PBR Eco-4  
1 pc. #3 Pipe Boot

You are now ready to order your new metal roof. If you have any questions, or need you materials list checked, please contact your local authorized AFP Metal Products dealer.

**ECO Rib-5 & PBR Eco-4 Order Form**

Panels: Color = \_\_\_\_\_

Accessories:

\_\_\_\_\_ pcs. @ \_\_\_\_\_ ft. \_\_\_\_\_ in.  
\_\_\_\_\_ pcs. @ \_\_\_\_\_ ft. \_\_\_\_\_ in.  
\_\_\_\_\_ pcs. @ \_\_\_\_\_ ft. \_\_\_\_\_ in.  
\_\_\_\_\_ pcs. @ \_\_\_\_\_ ft. \_\_\_\_\_ in.  
\_\_\_\_\_ pcs. @ \_\_\_\_\_ ft. \_\_\_\_\_ in.  
\_\_\_\_\_ pcs. @ \_\_\_\_\_ ft. \_\_\_\_\_ in.  
\_\_\_\_\_ pcs. @ \_\_\_\_\_ ft. \_\_\_\_\_ in.  
\_\_\_\_\_ pcs. @ \_\_\_\_\_ ft. \_\_\_\_\_ in.

\_\_\_\_\_ pcs. Of Eave Flash \_\_\_\_\_ (flashing code)  
\_\_\_\_\_ pcs. Of Ridge Flash \_\_\_\_\_  
\_\_\_\_\_ pcs. Of Gable Flash \_\_\_\_\_  
\_\_\_\_\_ pcs. Of Sidewall Flash \_\_\_\_\_  
\_\_\_\_\_ pcs. Of Endwall Flash \_\_\_\_\_  
\_\_\_\_\_ pcs. Of Valley Flash \_\_\_\_\_  
\_\_\_\_\_ pcs. Of Transition Flash \_\_\_\_\_  
\_\_\_\_\_ pcs. Of Gambrel Flash \_\_\_\_\_  
\_\_\_\_\_ pcs. Of Peak Flash \_\_\_\_\_  
\_\_\_\_\_ pcs. Of J Channel \_\_\_\_\_  
\_\_\_\_\_ pcs. Of #14 x 1" or 1½" MP Painted Screws  
\_\_\_\_\_ pcs. Of Tube Caulk  
\_\_\_\_\_ pcs. Of Butyl Sealant Tape  
\_\_\_\_\_ pcs. 1 x 1 x 13.2' Sealer Strip

## NEW ROOFS

1. Make sure there are no nails or other objects protruding from the substrate that might puncture the underlayment or damage the roof panels. Clean all debris from the deck. Check for any high or low spots in the deck, which will cause waviness in the metal panels.
2. Check all details for possible roof penetrations, which must be added to the deck prior to roof panel installation (vented ridge for example).
3. Cover the entire roof deck with 30-pound felt paper, Perma-Felt or equivalent (hereinafter referred to as underlayment). Begin at the eave at the gable end and roll out the underlayment horizontally (parallel to the eave). Allow each consecutive course to overlap the previous one at least 4". Overlap the end a minimum of 6" when starting a new roll of underlayment. Areas of underlayment that have been torn or cut should be replaced or repaired prior to installation of the metal roof. (See Illustration #1)

**ILLUSTRATION #1**

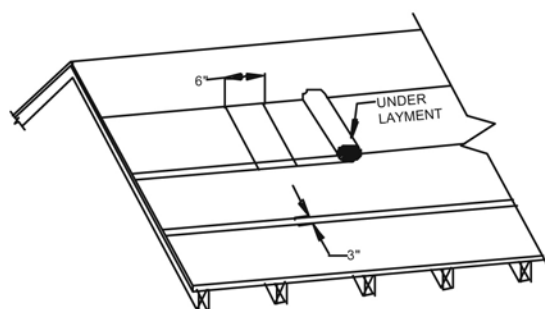

4. Place an alignment line along the gable end where the first roof panel will be installed. THIS LINE SHOULD BE LOCATED 1/2" IN FROM THE GABLE EDGE OF THE ROOF DECK AND SQUARE WITH THE EAVE LINE. Various methods exist for insuring that the line is square. Call your authorized AFP Metal Products dealer if you need assistance. (See Illustration #2)

**ILLUSTRATION #2**

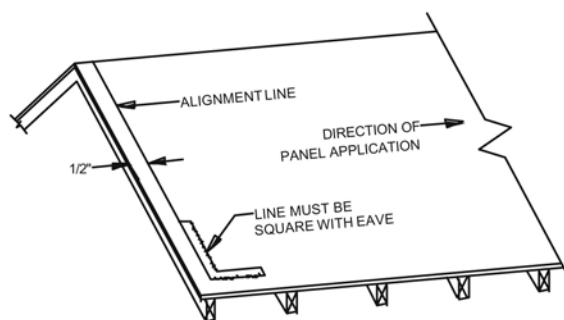

## EXISTING ROOFS

In many cases, AFP's Steel Roofing Panels can be installed over existing roofing.

Some jurisdictions will allow retrofit over certain types of roofing without tear-off of the old roofing. Check with your local codes or building department for the specific requirements in your area.

If the roof is to be stripped down to the existing decking, follow the procedures for new roofs on page 7. Be sure to check the existing roof and repair any damaged areas prior to installation of the new roof system.

The following steps should be taken when installing new metal roof panels over existing roofing.

1. Inspect the roof for damage and make the necessary repairs.
2. Secure any warped or loose roofing.
3. Make sure there are no nails or other objects protruding from the roof that might puncture the new underlayment or damage the new roof panels.
4. Remove all moss and other debris from the roof.
5. Cut off any overhanging roofing flush with the roof deck, and remove all hip and ridge caps.

Note: For best results, Metal Roofing requires a relatively smooth and flat substrate.

Application over rough and/or uneven surfaces is not recommended.

## PANEL INSTALLATION

Note: Prior to panel installation, determine which items need to be installed prior to panels (such as eave, valley, swept wing, etc.)

1. Working off the eave edge, establish a straight line up the gable edge from which you are starting. This will insure that the first panel laid will be straight and square with the eave. (See Illustration #2)
2. Before fastening the panel to the roof deck, check to make sure that the panel is overhanging the eave by 1".
3. Once the first panel is in proper position, secure it to the roof deck with #14 fasteners per the standard fastening pattern.
4. Set the gable trim into a bead of butyl tape and screw it to the fascia board (see page 15). This fully secures the first panel to the roof deck.
5. Position the second panel (overlap edge on top of the underlap edge of first panel) assuring that the eave edge is in position (1" overhang). Secure the second panel to the deck with #14 fasteners.
6. Each consecutive panel will be installed in the same manner.

## STANDARD TRIM PARTS

### Key Terms

#### 1 RIDGE CAP

This piece is used at the peak of a typical two-slope roof. The ridge can be ventilated, by using Profile Vent in place of sealant and outside closures.

#### 14 HIP CAP

This piece covers projecting angles formed at the intersection of the two sloping roof planes.

#### GABLE TRIM

This piece is installed on the house between the ridge and the eave, holding down the first panel edge and the last panel edge. Gable -trim seals out the weather and gives a neat finished appearance.

#### 5 EAVE TRIM

This piece is used at the eave or gutter edge of the building, and must be installed before any panels.

#### 2 W-VALLEY

Used to flash the valley formed by intersecting roof planes.

#### 9 SIDEWALL

This piece is used when the roofing panel is installed parallel to a vertical wall.

#### 6 ENDWALL

This piece is used when the upper end of panel butts into a vertical wall.

#### 8 SLOPE TRANSITION

This piece is used where two roofs of different pitch meet, the top section being steeper than the lower section.

#### 7 GAMBREL CONDITION

This trim is used to transition from low-slope panels on the top section to steep-slope panels on the lower section.

#### CHIMNEY OR SKYLIGHT

See pages 17 -19

#### FASTENERS

##### #14 X 1" MILL POINT SCREW

This fastener is used to attach trim to the panels, and also to attach panels directly to the roof deck.

##### #14 x 1½" MILL POINT SCREW

This fastener is used to attach trim through the high rib of the panel, and also to attach panels to the roof deck.

This list of flashing can be used in conjunction with the Home Legend drawing on the next page to help you understand placement and proper installation.

## ECO Rib-5 & PBR Eco-4

### FASTENERS

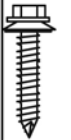
# Fasteners	Description	Use
	#14 x 1" Mill Point Screw 	Panels and Trim
	#14 x 1 1/2" Mill Point Screw 	Panels and Trim

Note the diagram below for proper installation of gasketed fasteners.

#### PROPER INSTALLATION OF GASKETED FASTENERS



#### Load span Tables for 29 ga. EPR & PBR

ALLOWABLE LIVE LOAD (psf) for 29 ga. 80 ksi PANELS Purlin Or Nailers Spacing (ft.)

Spans		1.0	1.5	2.0	2.5	3.0
<b>3 OR MORE</b>	Load (psf)	450	200	112	72	50

Note: Live loads are based on panel load capacity only and do not apply to load capacity of trusses, purlins, or decking.

### Load span Tables for 29 ga. EPR & PBR

#### ALLOWABLE WIND UPLIFT LOADS (PSF)

Substrate	Fastener	9"	12"	15"	18"	21"	24"
3/4" Plywood	#14 x 1" MP	261.1	195.0	156.5	130.5	111.5	97.5
5/8" Plywood	#14 x 1" MP	242.0	181.5	145.3	121.0	103.5	90.5
1/2" Plywood	#14 x 1" MP	165.0	123.5	99.0	82.5	70.5	61.75
7/16" OSB	#14 x 1" MP	99.5	74.5	59.7	49.75	42.5	37.0
19/32" OSB	#14 x 1" MP	122.0	91.5	73.0	61.0	52.0	45.75
23/32" OSB	#14 x 1" MP	181.5	136.0	109.0	90.75	77.75	68.0
Solid 2x SPF	#14 x 1" MP	313.8	235.3	188.3	156.9	134.5	117.6
Solid 1x Pine	#14 x 1" MP	313.8	235.3	188.3	156.9	134.5	117.6
Screws	per Sq.	190	150	120	100	90	80



Listed above are the fasteners recommended for the proper installation of the Metal panels.

## PBR Eco-4 or ECO RIB 5

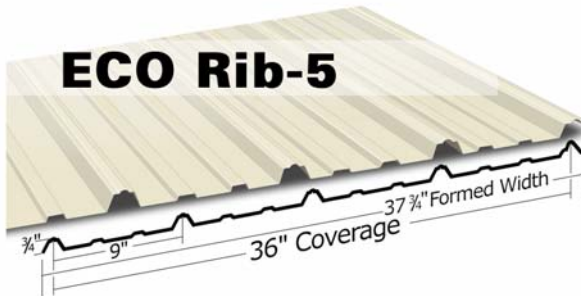
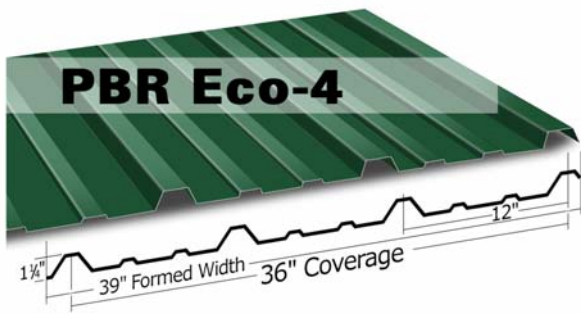

ENERGY STAR®  
QUALIFIED

Architectural exposed fastener panel. 9 in., on center, spacing major ribs with equally spaced stiffening ribs. 3/4 in. major rib height. Minimum Slope is 3:12.

**Typical Applications:** Architectural, Residential, Light Commercial/Industrial, Post-Frame Buildings, Garages, Porches, Gazebos. Retrofit over existing roof.

### FLASHING AND TRIM



## FLASHING & TRIM PRICING

Lineal Trims and Flashings are sold in 10' 6" lengths unless otherwise specified.

	Unit	Model	Description
1	Each	TARC-1-xxx	Ridge Cap
2	Each	TAWV-1-xxx	Preformed Valley
3	Each	TAMG-1-xxx	Gable Flashing
4	Each	TAZ-1-xxx	Drip Cap (use with metal siding)
5	Each	TAME-1-xxx	Eave Flashing
6	Each	TAEW-1-xxx	Endwall Flashing
7	Each	TDGT-1-xxx	Gambrel Flashing
8	Each	TATRF-1-xxx	Transition Flashing
9	Each	TASW-1-xxx	Sidewall Flashing
10	Each	TAIC-1-xxx	Inside Corner Flashing
11	Each	TABG-1-xxx	Base Drip (use with metal siding)
12	Each	TAE-1-xxx	Eave Flashing
13	Each	TAZ-1-xxx	Double Angle (use with metal siding)

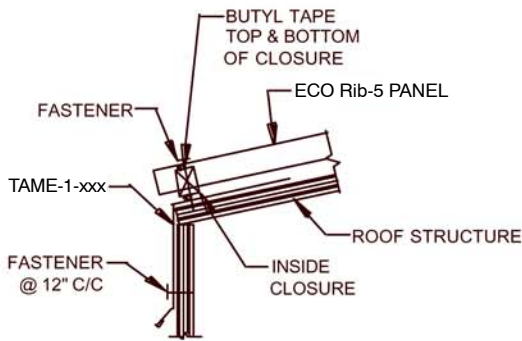

## EAVE DETAIL

### Notes:

1. Roofing underlayment not shown.
2. Tack the eave flashing in place under the underlayment using roofing nails.
3. Install the panels and closures as shown, allowing ½" to 1" of hang at eave.

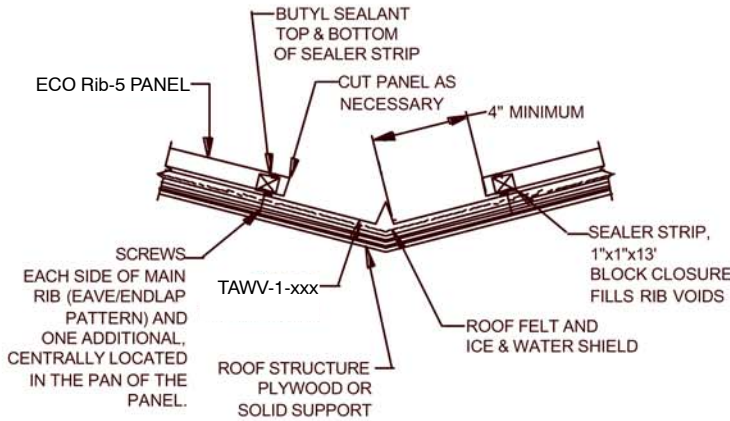

## VALLEY DETAIL

### Notes:

1. Roofing underlayment not shown.
2. Place a second layer of 36" roofing underlayment in the centerline of the valley with 18" of underlayment on each side of the valley.
3. When valley flashing is overlapped, 6" of lap is recommended with sealant applied under the lap.
4. Install sealant and 1 x 1 x 13' sealer strip as shown.
5. Field cut the roofing panels holding back 4" from valley as shown.
6. Fasten the panels through the valley flashing as shown with fasteners on both sides of each main rib. In applications with extreme angles, an additional fastener may be needed between ribs.

## START GABLE DETAIL

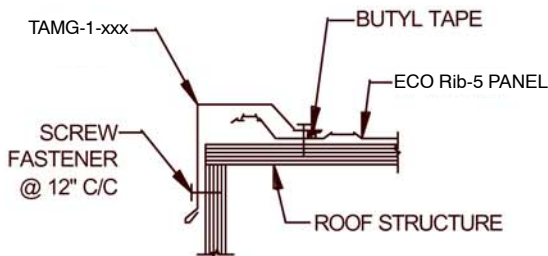

## FINISH GABLE DETAIL

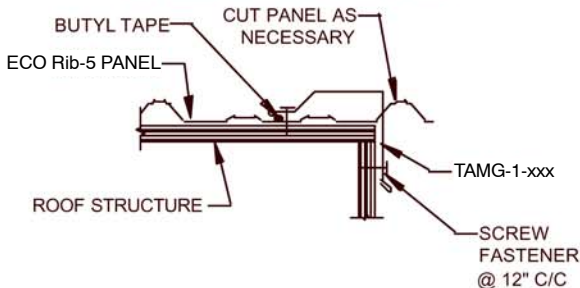

### Notes:

1. Roofing underlayment not shown.
2. Install the gable trim by placing it over the edge of the roof as shown and fasten it to the fascia board at 12" on center.
3. The eave end of the gable-trim can be closed-off by snipping and folding.
4. For gable detail at ridge, see page 15.
5. When the last roof panel extends past the roof, trim panel and finish as shown to left.

## RIDGE & GABLE DETAILS

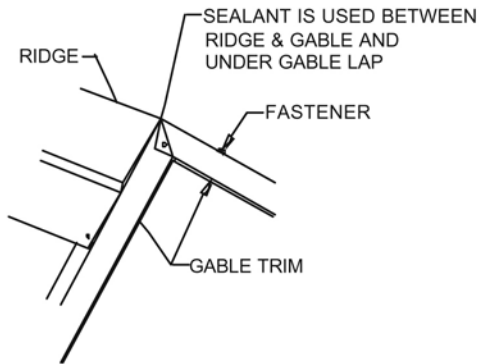

## RIDGE DETAIL

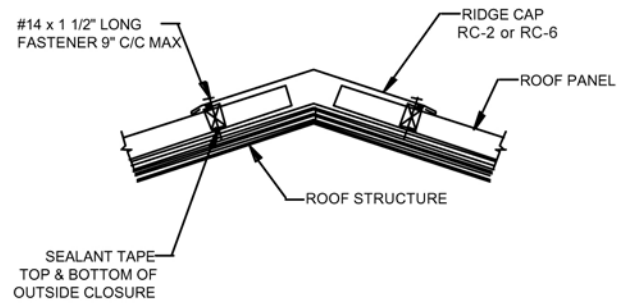

## VENTED RIDGE

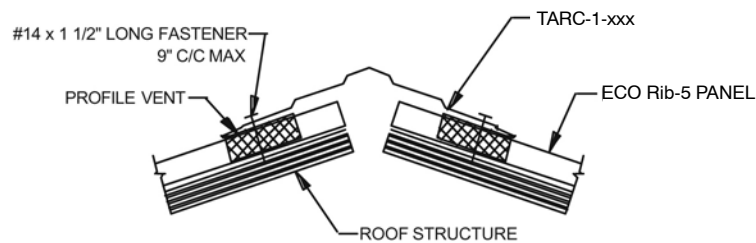

### Notes:

1. Roofing underlayment not shown.
2. Plywood should be held back or cut back 1½" from each side of the ridge.
3. Attach the panels checking the 1" minimum overhang at the eave.
4. Mark edge of ridge cap on both sides of the peak. Unroll profile vent and press into place about 1" upslope of mark.
5. The gable flashing must be installed prior to the ridge installation.
6. Fasten the ridge cap using #14 x 1½" MP screws on each panel rib 1" back from the edge of the profile vent

## HIP DETAIL

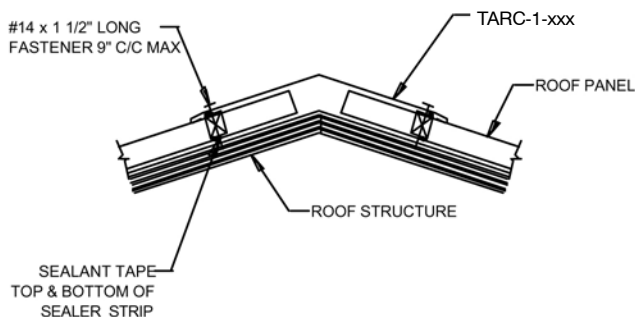

## HIP ROOF—PLAN VIEW

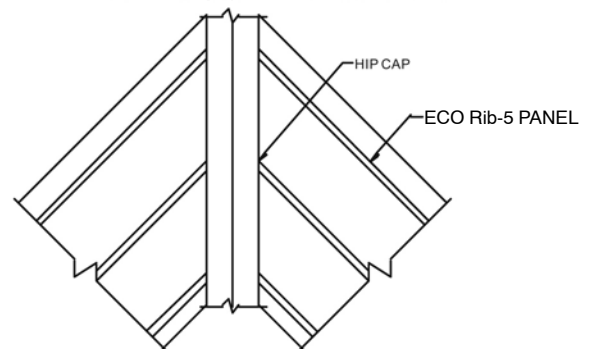

### Note:

1. Hip flashing attachment same as ridge (see detail above).

## MONOSLOPE PEAK

### Notes:

1. Roofing underlayment not shown.
2. Apply sealant to the bottom of the foam closure and position it on the roof panel approximately ½" - 1" back from the edge of the flashing as shown.
3. Apply sealant to the top of the foam closure.
4. Install flashing as shown.
5. When more than one length of flashing is used, a 6" minimum overlap is recommended. Apply sealant between the laps

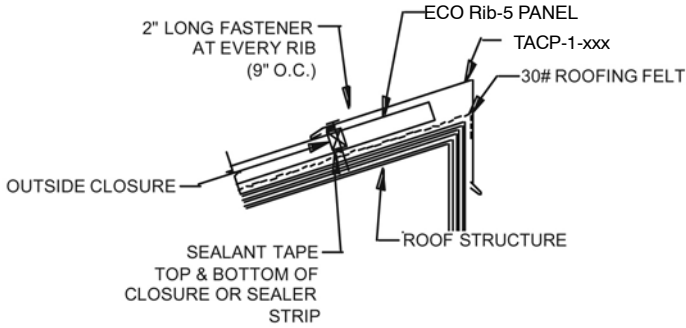

## ENDWALL DETAIL

### Notes:

1. Roofing underlayment not shown.
2. Install the foam closure as shown using sealant on the top and bottom.
3. Install endwall flashing as shown.
4. When more than one endwall is needed, a 6" minimum overlap is recommended with sealant between the laps.

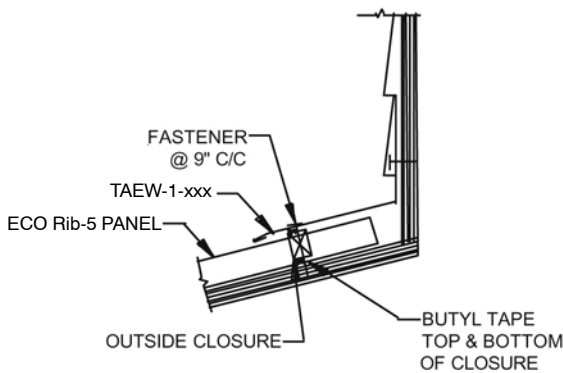

## SIDEWALL DETAIL

### Notes:

1. Roofing underlayment not shown.
2. The sidewall flashing is placed over the panel rib and placed behind the siding as shown.
3. When the panel rib does not end up next to the wall, cut the panel and bend a 1" return flange.

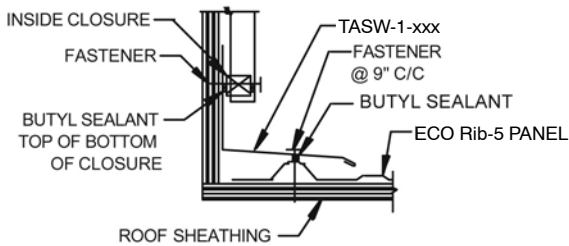

## SWEPT WING GABLE

### Notes:

1. In high rain & snow areas, it is recommended that you use a high-grade underlayment, such as ice and water shield, along the entire swept wing gable.
2. Roofing underlayment not shown.
3. Install the 1 x 13' sealer strip with a bead of butyl sealant tape top and bottom.
4. Cut panels to fit the gable angle and align downslope edge.
5. Fasten the panels through the flashing and into the deck using #14 Mill Point screws per the standard eave fastening pattern.

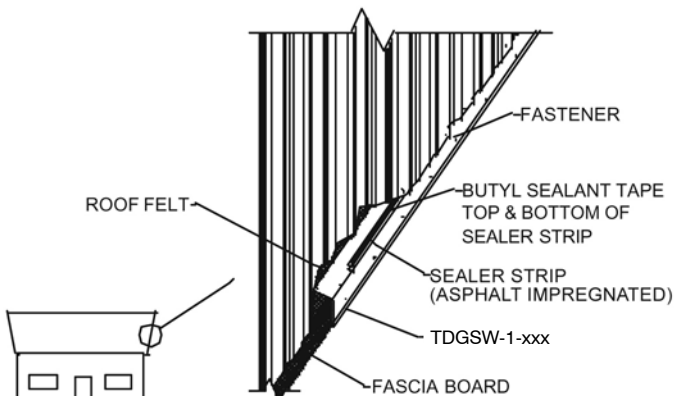

## GAMBREL DETAIL

### Notes:

1. Roofing underlayment not shown.
2. Bottom panels of the slope transition must be installed first.
3. Mark the location of the foam closure and place a bead of butyl sealant tape on the panels. Install the closures and a second bead of sealant on top of the closures.
4. Install TDGT-1-xxx Transition trim using #14 x 1½" MP screws into each rib of the bottom transition panels, 9" o.c.
5. Apply sealant as indicated above.

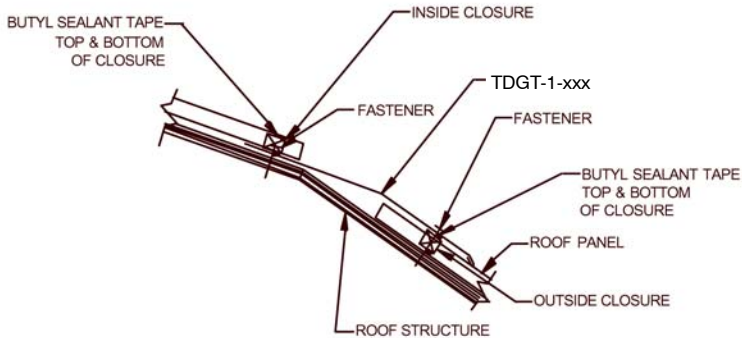

## SLOPE TRANSITION (WOOD FRAMING)

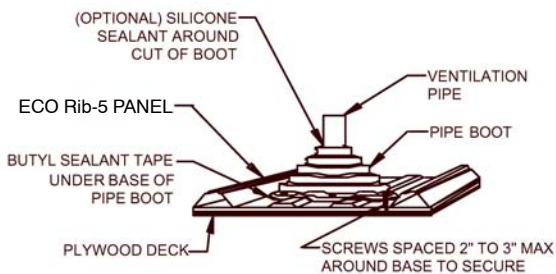
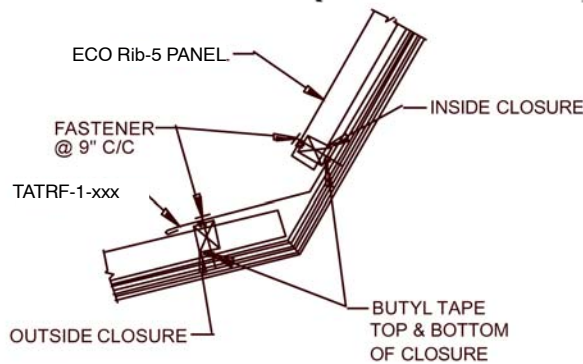

## PIPE FLASHING

### Notes:

1. Cut the hole in the flashing 20% smaller than the pipe diameter.
2. Slide the flashing down the pipe.
3. Form the flashing to the roof profile.
4. Apply sealant around the perimeter of the flashing base and fasten to roof using #14 x 1" fasteners.

## CRICKET FIELD FORMED

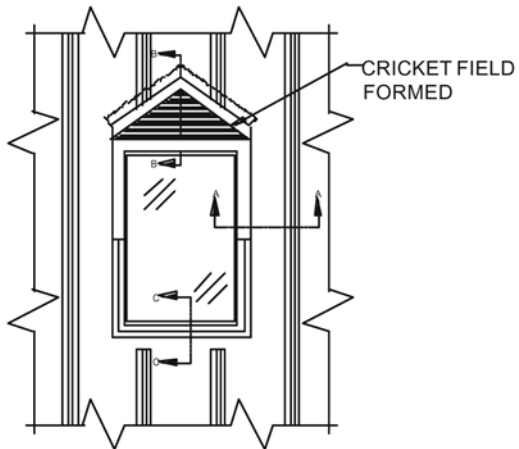
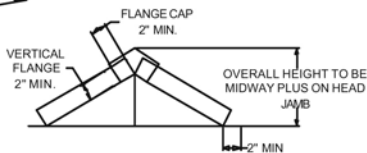
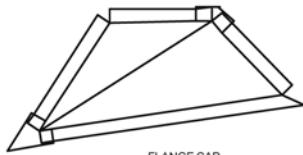
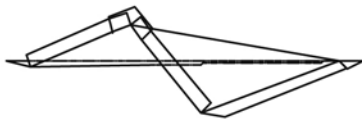
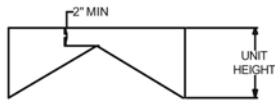
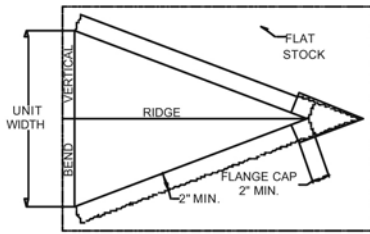

### Notes:

1. Trim both ends of the uphill and downhill sides of the skylight flashing as indicated.
2. Slide the uphill flashing into the slots cut into the roofing and apply a liberal amount of sealant.
3. Assemble the skylight.

### Notes:

1. Whenever possible, position the skylight curb so the ribs of the roof panels do not interfere with the flashing.
2. Cut the roofing panels as close to the left, right and downhill sides of the curb as possible. Cut the uphill side within 1" of the valley formed by the cricket.
3. The skylight flashings should be 4" wider than the width of the curb (2" on each side).
4. Install with 1 x 1 sealer and sealant per Detail B-B on page 20.

## SKYLIGHT FLASHING PREPARATION

### Detail "A-A"

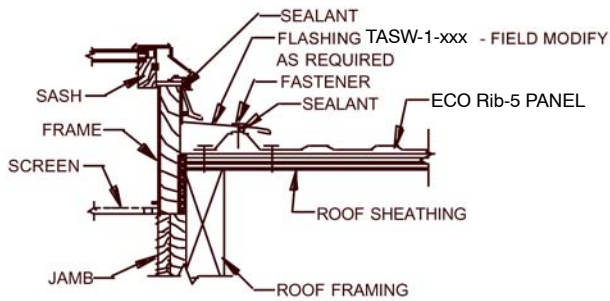

### ALTERNATE DETAIL "A-A"

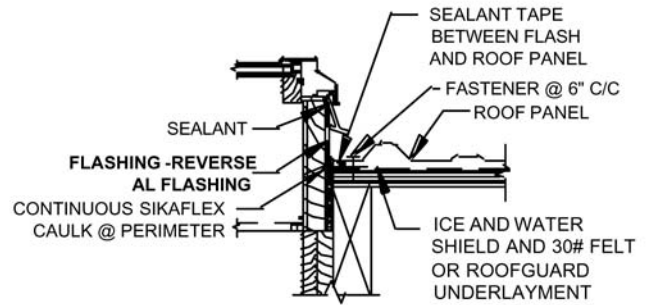

### Notes:

1. Trim and bend the right side skylight flashing to fit as necessary.
2. Trim the left side in a similar fashion.

### SKYLIGHT DETAIL "B-B"

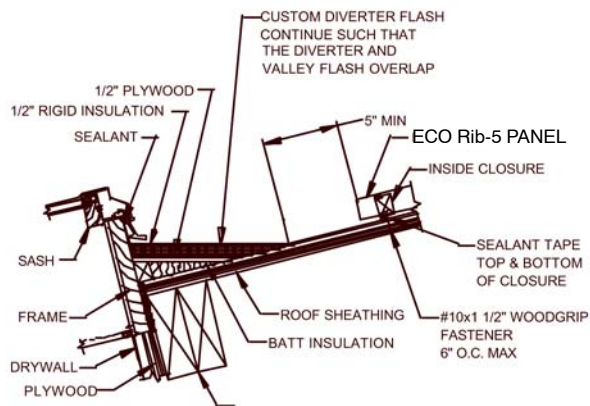

### SKYLIGHT FLASHING (SIDE) DETAIL "C-C"

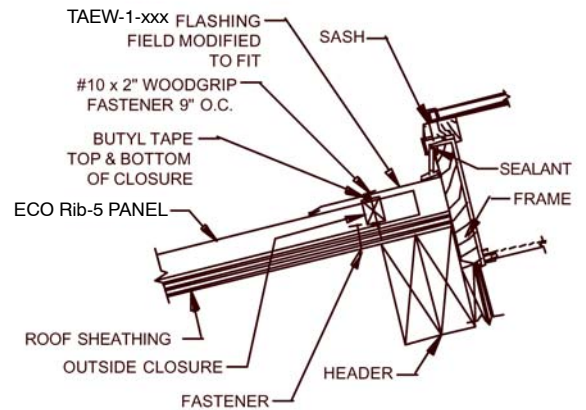

## CHIMNEY FLASHING

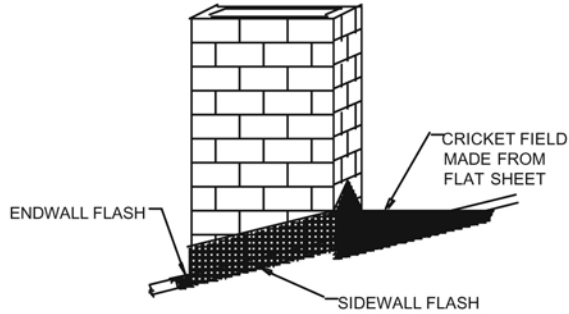

### Notes:

1. Procedures for the installation of Chimney Flashings are similar to the Skylight's (refer to pages 17 & 18).

2. The saw-cut reglet shown provides the best weathertight installation for chimneys. Fill the reglet with sealant, insert trim and fasten as necessary w/masonry anchors.

3. Flashings may be field-formed from 40 13/16" x 10' flat sheets.

### CHIMNEY FLASHING (SIDE)

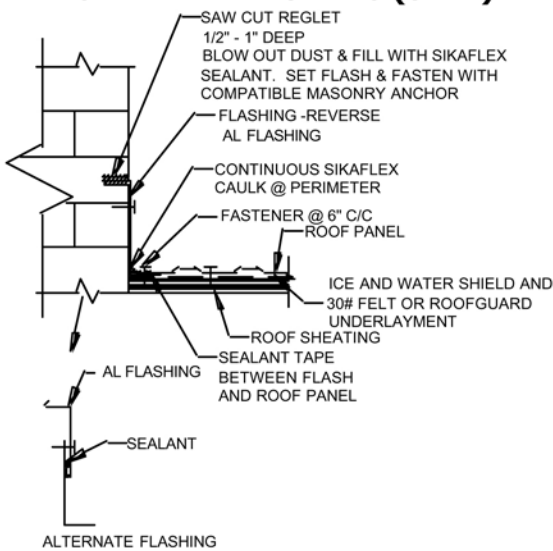

### CHIMNEY FLASHING (UPHILL SIDE)

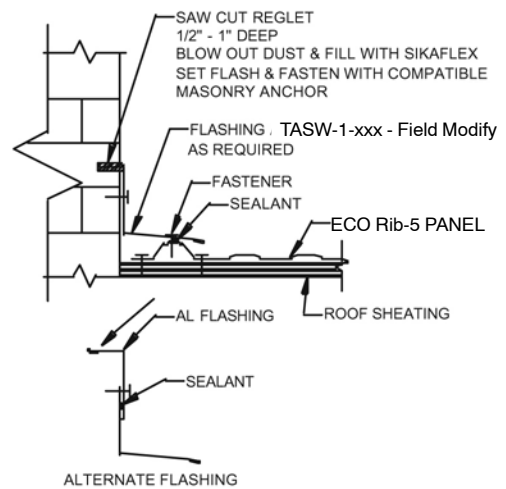

### CHIMNEY FLASHING (DOWNHILL SIDE)

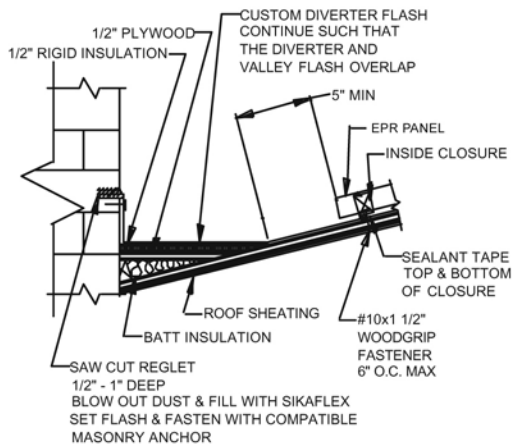

### CHIMNEY (ALTERNATE SIDE)

